

Lonestar Truck Group
InGear Newsletter
Promoting Trucking with Value
June 2012

inGear



LONESTAR
TRUCK GROUP



Lonestar Truck Group is Your One-Stop Source for

TRUCK & TRAILER SALES, PARTS & SERVICE

■ Jody Milligan runs log trucks out of Garvin, OK. Jody has a 16 truck Fleet and is currently running several brands of trucks, but prefers the Western Stars due to the rough and rugged terrain they run on. Jody is running 4 new Western Star 4900FA's with DD15's and 2 Western Star 4900EX Gliders that he put together. ■ Pictured above is the first glider that he assembled and it features a 10 speed, 3:90's with full lockers and a single turbo C15. It took Jody and his crew about five business days to build the glider. He is currently building a second Glider which features a 15 speed, 3:90's with full lockers and a Series 60 550 HP Detroit. The Western Stars are perfectly suited for the logging industry and continue to help his company grow. ■ Jody is a customer of Greg Fouche of Texarkana Truck Center, a member of the Lonestar Truck Group.



SERIOUS TRUCKERS — SERIOUS TRUCKS:

Top, Kaiden McBrayer. Bottom, left to right are Luis Roque, Kolten Lambe, Matt Ward, and trucking company owner, Jody Milligan.

June 2012

www.LonestarTruckGroup.com

LONESTAR PARTS SPECIALS



TDA-R12105	DRAIN VALVE	\$9.95 ea
FUL-K3494	SYNCHRONIZER KIT	199.95 ea
FUL-A5000	SLAVE VALVE ASSEMBLY	74.95 ea
FUL-S1659	INPUT SHAFT ASSEMBLY	67.95 ea
SP-5003323	CENTER BEARING ASSEMBLY	58.95 ea
HDX-BK313	2" HINGED CLUTCH BRAKE	26.95 ea
FLF-FRE1020-0001	4" X 6" CHARGE AIR HOSE	13.95 ea
STM-393-0173	STEMCO DRIVE AXLE SEAL	34.95 ea
STM-383-0136	STEMCO STEER AXLE SEAL	25.95 ea
KYS-1090-09600-01	FAN HUB	379.95 ea
ABP-N60C-8039S	QUILTED INNERSPRING MATTRESS	169.95 ea

PARTS PICTURES ARE FOR REFERENCE ONLY. ACTUAL PARTS MAY VARY.
Prices good through June 30 2012

LUCAS OIL PRODUCTS SALE



10001	HEAVY DUTY OIL STABILIZER - QT	\$7.95 \$90.00	Per Quart 1/1 Per Case 12/1
10002	HEAVY DUTY OIL STABILIZER - GAL	\$21.95 \$83.80	Per Gallon 1/1 Per Case 4/1
10003	LUCAS FUEL TREATMENT - QT	\$6.95 \$78.00	Per Gallon 1/1 Per Case 12/1
10013	LUCAS FUEL TREATMENT - GAL	\$19.95 \$75.80	Per Gallon 1/1 Per Case 4/1
10088	HUB OIL - 32 OZ	\$5.95 \$66.00	Per Quart 1/1 Per Case 12/1
10005	RED "N" TACKY #2 GREASE	\$2.99 \$2.75	Per Tube 1/1 Each - 10 or More

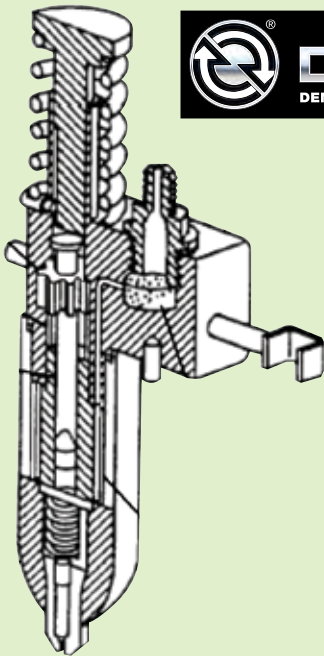

\$680 Labor

**TO REPLACE:
6 Detroit Reliablilt fuel injectors and you receive
a 2 year/150K mile Power Pack Warranty.**

Note: Less that 6 injectors carry standard 1 year warranty.
Only Detroit Series 60 Engines and MBE 4000 Engines are included in the special labor pricing.
Pricing for injectors varies by Engine model and serial number, see our parts department for pricing on injectors to fit your engine.
Prices good through June 30, 2012

LONESTAR TRUCK GROUP



■ **CORLEY-WETSEL
FREIGHTLINER - WESTERN STAR**
ABILENE, TX 1-800-535-0826

■ **ALBUQUERQUE
FREIGHTLINER - WESTERN STAR**
ALBUQUERQUE, NM 1-800-535-6470

■ **BRYAN
FREIGHTLINER - WESTERN STAR**
BRYAN, TX 1-866-727-9222

■ **FARMINGTON
FREIGHTLINER WESTERN STAR**
FARMINGTON, NM 1-800-535-9031

■ **CORLEY
FREIGHTLINER - WESTERN STAR**
SAN ANGELO, TX 1-800-901-9973

■ **SHREVEPORT TRUCK CENTER**
SHREVEPORT, LA 1-877-700-9955

■ **TEMPLE
FREIGHTLINER - WESTERN STAR**
TEMPLE, TX 1-800-903-6177

■ **TEXARKANA TRUCK CENTER**
TEXARKANA, TX 1-866-940-8444

■ **TYLER TRUCK CENTER**
TYLER, TX 1-877-600-2575

■ **WACO
FREIGHTLINER - WESTERN STAR**
WACO, TX 1-888-700-9735

■ **WICHITA FALLS
FREIGHTLINER - WESTERN STAR**
WICHITA FALLS, TX 1-800-903-0322

LABOR SPECIAL

BRAKE SHOES INSTALLATION PER AXLE...

\$15000

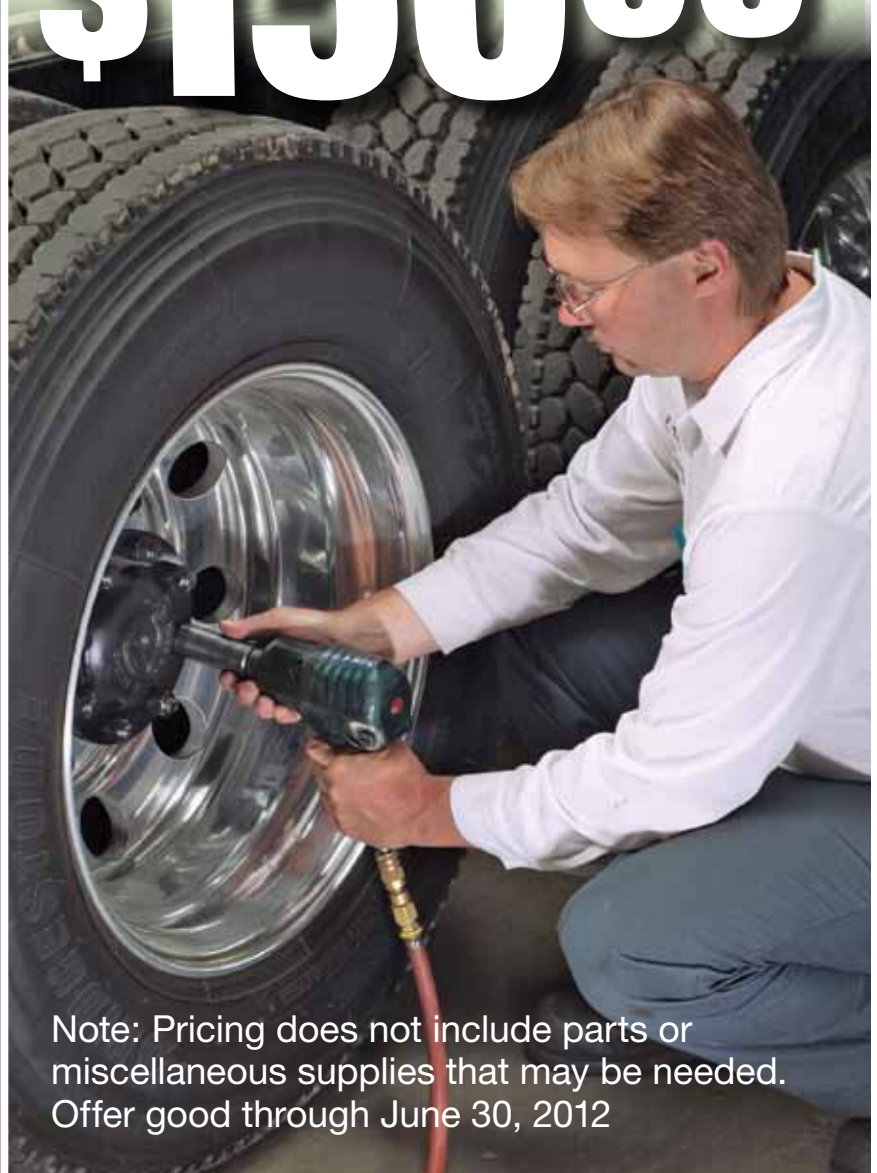

Note: Pricing does not include parts or miscellaneous supplies that may be needed. Offer good through June 30, 2012

Call any Lonestar location.

You drive... Leave the service to us.

Lonestar Truck Group

MANAGERS' SPECIALS



2009 Freightliner FLD12064SD, DDC 14.0 Detroit Engine 490 hp; Diesel; 10 Spd OD; Engine Brake; Air Ride Suspension; 3.90 Ratio; 24.5 Tires; Aluminum Outside Wheels; 212 in Wheelbase, New Tires, 525,000 Miles. (9DAE2552-ABL-1) ~~\$67,500~~



2008 International Prostar, (Qty 2) Mid Roof Sleeper; ISX Cummins Engine 485 hp; Diesel; 498,563 mi; 13 Spd OD; Eng. Brake; Air Ride; 3.55 Ratio; 22.5 Tires; Alum Wheels; 12,000 lb Front Axle Wt; 40,000 lb Rear Axle Wt, 498,563 Miles. (8C538659-ABQ-1) ~~\$64,900~~ **\$54,900**



2007 Freightliner C12064ST Century 120, 70 in Mid Roof Sleeper; MBE4000 Mercedes Eng 455 hp; Diesel; 10 Spd OD; Engine Brake; Air Ride; 3.42 Ratio; 22.5 Tires; Aluminum Wheels; 242" WB; 511,000 Miles. (7LZ50193-BRY-1) ~~\$41,900~~ **\$37,900**



2012 Western Star 4964SA Vacuum Tank Truck, Cummins 485 hp; Diesel; 8LL; Engine Brake; TufTrac Susp; 4.30 Ratio; Aluminum/Steel Wheels; 227 in WB; 24.5 Tires; 46,000 lb Rear Axle Wt; 14,600 lb Front Axle Wt. **New** (CPBK9610-FAR-1) ~~\$167,000~~ **\$166,500**



2008 Transcraft Flat Bed, 53' x 102", Air Ride Suspension, Tandem Axle, 11R24.5 Tires, Steel Wheels, Hardwood Floors. (81084591-SAN-TRL-1) **\$18,500**



2007 Kenworth T600, 72 in Aerocab Aerodyne Sleeper; ISX Cummins Engine 450 hp; Diesel; Automatic OD; Engine Brake; Air Ride; 3.36 Ratio; 22.5 LP Tires; All Aluminum Wheels; 240 in Wheelbase. (7J189869-SHV-1) ~~\$49,700~~ **\$43,500**



2009 Freightliner Cascadia, 72 in Raised Roof Condo; DD 15 Detroit 475 hp; Diesel Fuel Type; 10 Spd OD; Engine Brake; Air Ride; 3.58 Ratio; LP 22.5 Tires; All Aluminum Wheels; 240" WB; 430,000 Miles. (9LAC0386-TEM-1) **\$68,500**



2012 Western Star 4900, Detroit Diesel DD15, 505 HP, 10 Spd, Engine Brake, Air Ride, 230" WB, 24.5 Tires, Aluminum Front Wheels, Steel Rear Wheels, 5 Year/500,000 Mile Engine Warranty. **New** (CPBM9285-TXK-1) **\$128,759**



2005 Kenworth T2000, 72 in Condo Sleeper; C15 Caterpillar Engine 435 hp; Diesel; 10 Spd OD; Engine Brake; Air Ride; 3.36 Ratio; 22.5 LP Tires; All Aluminum Wheels; 240 in Wheelbase; Tandem Axle, 628,546 Miles. (5J058140-TYL-1) **\$28,500**



2005 International 9400i, 51 in Mid Roof Sleeper; ISX Cummins Engine 450 hp; Diesel; 10 Spd OD; Engine Brake; Air Ride Suspension; LP 22.5 Tires; Aluminum Wheels; Tandem Axle, 737,000 Miles. (5N137597-WAC-1) **\$27,950**



2007 Freightliner Columbia 120, 70 in Raised Roof Condo; Detroit Engine 490 hp; 10 Spd OD; Engine Brake; Air Ride Suspension; 3.42 Ratio; 24.5LP Tires; All Aluminum Wheels; 235 in Wheelbase; Tandem Axle, 620,000 Miles. (7LW76277-WF-1) **\$45,900**



2007 Wabash Combo Flatbed, (Qty: 8) Air Ride Susp; 48 ft Long x 102 in Wide; Alum. Floor; 22.5 Tires; All Steel Wheels; Spread Tandem Axle; Combination Comp; 48x102 Combo Flatbed. (72020630-SHV-TRL-1A) **Call for Price**

Lonestar Truck Group is your place for quality used trucks.



2008 International 9900 Mid-Roof Sleeper, Caterpillar C15, 475 HP, 13 Spd, 3.58 Ratio, Engine Brake, Air Ride, 22.5 LP Tires, All Aluminum Wheels, 509,000 Miles. 6 Months 50K Miles NTP Engine Warranty. (8C637335-ABL-2) ~~\$68,500~~ **\$61,500**



2009 Sterling L9500, DD15 Detroit 560 hp; ; Diesel Fuel Type; 18 Spd OD; Eng Brake; Air Ride; 4.10 Ratio; 24.5 Tires; Alum Wheels; 196 in WB; 14,000 lb Front Axle Wt; 46,000 lb Rear Axle Wt, 233,000 Mileage. (9AAB0130-ABL-3) **\$67,500**



2010 Freightliner Sprinter 2500, V6 Diesel Mercedes Eng. 188 hp; Diesel; 40 mi; Automatic OD; Spring Susp; Steel Wheels; Single Axle; 11 Passengers; 144 in WB, 2010 Emissions. **New.** (A5498817-ABQ-2) ~~\$49,900~~ **\$39,900**



2011 Freightliner M2 106, Standard Cab; ISB Cummins 220 hp; 6 mi; 5 Spd; Spring Susp; 5.13 Ratio; 22.5 Tires; Steel Wheels; 254" WB; Single Ax; 18,000 lb Rear Ax Wt; 8,000 lb Front Axle Wt, **New.** (BDAZ7404-ABQ-3) ~~\$59,900~~ **\$49,900**



2008 Freightliner CST120 Century, Detroit DDC 14.0, 500 HP, 10 Spd, Engine Brake, Air Ride Suspension, 22.5 LP Tires, All Aluminum Wheels, 462,430 Miles. (8LAA3520-BRY-2)



2012 Freightliner M2 106, Business Class, Cummins ISC, 260 HP, Allison Automatic Transmission, 5.13 Ratio, Air Ride Suspension 270" WB, 22.5 LP Tires, Steel Wheels. **New.** (CDBM6883-BRY-3)



2012 Western Star 4900SA, Cummins Engine 525 hp; Diesel; 18 Spd; Engine Brake; Air Ride; 4.30 Ratio; 24.5 Tires; All Aluminum Wheels; 260" WB; Tri Axle; 20,000 lb Front Axle Wt; 46,000 lb Rear Axle Wt. **New** (CPBM9529-FAR-2)



2012 Western Star 4900, (Qty: 2) Standard Cab; DD13 Detroit Engine 450 hp; Diesel; 8LL; Engine Brake; TufTrac; 4.30 Ratio; 24.5 Tires; Aluminum/Steel Wheels; 227 in Wheelbase; Tandem Axle, **New** (CPBM2894-FAR-3)



1984 Lufkin Oil Field Float, Spring Susp; 37 ft Long x 96 in Wide; Wood Floor; 24.5 Tires; Steel Disc Wheels; Fixed Tandem Axle; Steel Comp; Hard to Fine Used Oil Field Float With Rolling Tail Board. (E1064496-SAN-TRL-2)



2004 Nuva Van Trailers, (4 Qty) 48' x 102", Air Ride Suspension, Swing Doors. 11R22.5 Tires, Soft Side Steel Trailers, Apiton Floors. (41045455-SAN-TRL-3)



2005 Freightliner 13264T Classic XL, 70 in Condo Sleeper; C15 Caterpillar Engine 475 hp; Diesel; 13 Spd OD; Engine Brake; Air Ride Suspension; 22.5 LP Tires; Aluminum Outside Wheels; 259 in Wheelbase; Tandem Axle, 585,021 Miles. (5DN44632-SHV-2) ~~\$42,880~~ **\$42,500**



2013 Freightliner CA125 Cascadia, Detroit DD15, 475 HP, 10 Spd, Air Ride Susp, 22.5 LP Tires, All Aluminum Wheels, Warranty. **New.** (DSBM6811-SHV-3)

Many models & colors to choose from.



2012 Freightliner CC12264 Coronado, 48 in Sleeper; DD 15 Detroit Engine 505 hp; Diesel; 10 Spd OD; Engine Brake; Air Ride Suspension; 3.42 Ratio; 11R 24.5 Tires; Aluminum/Steel Wheels; 230" WB; Tandem Axle. **New.** (CDBM5408-TEM-2)



2012 Western Star 4900FA, ISX Cummins Engine 450 hp; Diesel; 10 Spd OD; Engine Brake; Air Ride Suspension; 3.70 Ratio; 11R 24.5 Tires; Aluminum/Steel Wheels; 215 in Wheelbase; Tandem Axle. **New.** (CDBW8000-TEM-3)



2006 Freightliner FLD132 Classic XL, 70" Sleeper, Caterpillar C15, 9 Spd, 3.58 Ratio, 260" Wheelbase. (6DU25708-TXK-2) **\$42,500**



2007 Freightliner CC13264 Coronado, 70 in Hi Rise Sleeper; S60 Detroit 515 hp; 13 Spd OD; Eng. Brake; Air Ride; 3.58 Ratio; 22.5 Tires; All Aluminum Wheels; 265 in WB, 825,760 Miles. (7PY20704-TXK-3) **\$43,800 \$39,500**



2000 International 9900, Caterpillar C12, 430 HP, 10 Speed, Air Ride, 24.5 Tires, Aluminum Front Wheels, Aluminum Outer Rear Wheels. 766,540 Miles. (YCO66784-TYL-2) **\$23,500 \$19,880**



2012 Freightliner Coronado SD, Cummins ISX, 500 HP, 18 Spd, Air Ride Suspension, 24.5 LP Tires, All Aluminum Wheels, Warranty. **New.** (CBK1043-TYL-3)



2004 Kenworth T2000, 72 in Raised Roof Sleeper; C-15 Caterpillar Engine 475 hp; Diesel; 10 Spd OD; Engine Brake; Air Ride; 3.55 Ratio; 22.5 Tires; All Aluminum Wheels; 230" WB; Tandem Axle; 1,000,000 Miles. (4J061674-WAC-2)



2009 Freightliner CA12564SLP Cascadia, 72 in Raised Roof Condo; 14.0 Detroit 500 hp; Diesel; 10 Spd OD; Engine Brake; Air Ride; 3.42 Ratio; LP 22.5 Tires; Aluminum Wheels; 230 in WB; Tandem Axle, 420,000 Miles. (9LAF0163-WAC-3)



2006 Kenworth T660, 72 in Premium High Roof; Caterpillar Engine 435 hp; Diesel; 13 Spd OD; Engine Brake; Air Ride; 3.58 Ratio; 22.5LP Tires; Aluminum Outside Wheels; 235" WB; Tandem Axle; 680,000 Miles. (6J109047-WFF-2)



2007 Freightliner CST12064 Century 120, 70 in Raised Roof Condo; Diesel Detroit Engine 455 hp; 10 Spd OD; Engine Brake; Air Ride; 3.58 Ratio; 22.5LP Tires; All Aluminum Wheels; 236" WB; Tandem Axle; 598,000 Miles. (7LX03451-WFF-3)



2013 Transcraft Combo Drop Deck, (Qty: 3) Air Ride; 53 ft Long x 102 in Wide; Alum. Floor; 22.5 Tires; Alum. Outside Wheels; Sliding Spread Tandem Axle; Combination Comp; Fixed Neck. **New.** (D3742652-SHV-TRL-2B) **\$Call for Price.**



2013 Transcraft Combo Flatbed, (Qty: 3) Air Ride Suspension; 48 ft Length x 102 in Width; Aluminum Floor; 22.5 Tires; Aluminum/Steel Wheels; Spread Tandem Axle; Combination Composition; Combo Flatbeds. **New.** (D3742658-SHV-TRL-3c)

Lonestar Truck Group
2051 Hughes Road
Grapevine, TX 76051

PRESORT STANDARD
U S POSTAGE
PAID
GLOBAL MAIL

RETURN SERVICE REQUESTED



LONESTAR
TRUCK GROUP

FREIGHTLINER



WESTERN STAR



TRUCK and TRAILER SALES, PARTS and SERVICE

www.LonestarTruckGroup.com / LS-1341 InGear Newsletter / ©Lonestar Truck Group, June 2012

Now at all Lonestar Dealerships

NATIONAL
TRUCK
PROTECTION

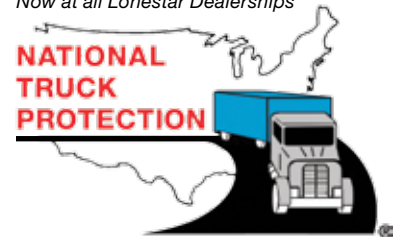

Lonestar Truck Group has over 70 new and used M2's in stock - ready for immediate delivery. The M2 is one of Freightliner's most versatile, durable, and reliable cab and chassis.

Used M2's - In Stock

- Box Van and RV Haulers
- Oil Field Gang/Roustabout Trucks
- Flat Beds and Stake Beds
- Lift Gates and 4-Door Models
- Conversions and Cab and Chassis
- Cummins, Cat, Mercedes Turbo Engines
- Allison Automatics
- Air Ride and Spring Ride Suspensions

All retail-ready used M2's include a 6-month 25,000 mile NTP Engine Warranty that includes Turbo and Injectors. Extended NTP coverage for Engine, Turbo, Injectors, Transmission, and Rear Axle up to 2 years/100,000 miles available for a very reasonable up-charge.

New M2's - In Stock

- RV Hauler Bed Trucks
- Conversions and Cab and Chassis
- 4-Door Models
- Cummins Turbo Diesels
- Allison Automatics and Manual Transmissions
- Air Ride and Spring Ride Suspensions

New M2's include a 2-year/unlimited miles warranty on the basic vehicle. Cummins turbo diesel engine includes 2-year/250,000 mile coverage.



Visit www.LonestarTruckGroup.com for a complete listing of our inventory.

