

Lonestar Truck Group  
InGear Newsletter  
Promoting Trucking with Value  
October 2011

**inGear**



**LONESTAR**  
TRUCK GROUP



Your one-stop source for  
**TRUCK and TRAILER SALES, PARTS and SERVICE**

**EXPRESS**  
**ASSESSMENT**

**Get In,**

**Get Diagnosed,**

**Get on the Road.**

### **It Pays to Run Clean**

When you have a problem with your rig, you need help right away to get back out on the road. You shouldn't have to wait for days just to find out that you needed a five-minute fix. And that's why Freightliner is rolling out its new Express Assessment.

### **You Can't Fix the Problem Before You Find It**

All Lonestar Truck Group dealers offer Express Assessment. When you bring your truck to one of the Lonestar Truck Group dealers, we promise to try and find the problem within two hours of your arrival. Lonestar Truck Group dealers will have a senior technician assess your truck within two hours of your arrival. After they find the problem, the tech can order any parts they need right away.





# LONESTAR TRUCK GROUP

■ **CORLEY-WETSEL**  
**FREIGHTLINER - WESTERN STAR**  
 ABILENE, TX 1-800-535-0826

■ **ALBUQUERQUE**  
**FREIGHTLINER - WESTERN STAR**  
 ALBUQUERQUE, NM 1-800-535-6470

■ **BRYAN**  
**FREIGHTLINER - WESTERN STAR**  
 BRYAN, TX 1-866-727-9222

■ **FARMINGTON**  
**FREIGHTLINER WESTERN STAR**  
 FARMINGTON, NM 1-800-535-9031

■ **CORLEY**  
**FREIGHTLINER - WESTERN STAR**  
 SAN ANGELO, TX 1-800-901-9973

■ **SHREVEPORT TRUCK CENTER**  
 SHREVEPORT, LA 1-877-700-9955

■ **TEMPLE**  
**FREIGHTLINER - WESTERN STAR**  
 TEMPLE, TX 1-800-903-6177

■ **TEXARKANA TRUCK CENTER**  
 TEXARKANA, TX 1-866-940-8444

■ **TYLER TRUCK CENTER**  
 TYLER, TX 1-877-600-2575

■ **WACO**  
**FREIGHTLINER - WESTERN STAR**  
 WACO, TX 1-888-700-9735

■ **WICHITA FALLS**  
**FREIGHTLINER - WESTERN STAR**  
 WICHITA FALLS, TX 1-800-903-0322

## Within an inch of your life!

**IF BRAKE SLACK EXCEEDS ONE INCH YOU COULD BE DRIVING A "KILLER TRUCK"**

Source: USDOT

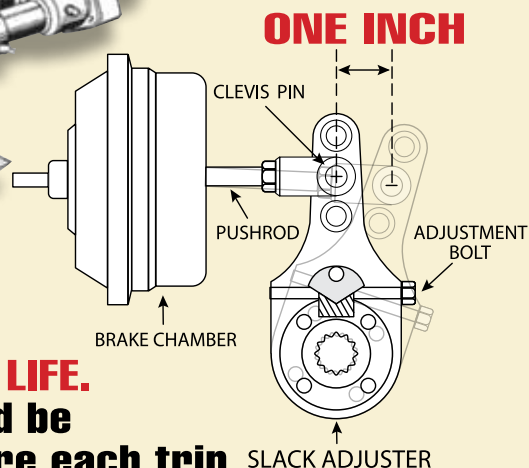
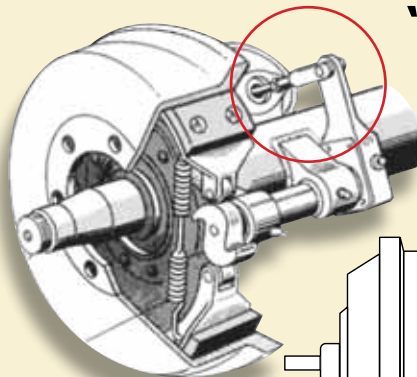

**THIS IS THE MOST IMPORTANT INCH OF YOUR LIFE.**

**Brakes should be checked before each trip and more frequently in hilly areas.**

TRUCKERS! Poorly adjusted brakes could cost you time and money with out-of-service violations, jeopardize your safety and that of others due to impaired stopping ability, and even cost you your life. The only way to be sure that your vehicle's brakes are properly adjusted is to physically check each wheel on a regular schedule. It is difficult for you to sense, simply from pedal feel, that your brakes are out of adjustment. Under normal braking conditions your brakes may respond satisfactorily, but under a hard or panic stop, you may find that you are unable to stop in time.

Source: USDOT

### Lonestar Truck Group Service Special

**FREE BRAKE INSPECTION**  
 with any labor purchase over \$100.00

#### BRAKE INSPECTION INCLUDES:

- *Inspect slack adjusters (if applicable).*
- *Inspect front and rear brake shoes.*
- *Inspect brake drums or brake rotors.*
- *Inspect wheel seals.*
- *Inspect all brake hoses.*

If repairs are necessary, parts and labor will be at additional cost. Offer good through October 31, 2011.

**SERVICE SATISFACTION... is standard equipment at Lonestar!**

October 2011

# LONESTAR PARTS SPECIALS

www.LonestarTruckGroup.com



<b>MLT-2042-30</b>	<b>4"x 30' Winch Strap with Flat Hook</b>	<b>\$8.95 ea</b>
<b>MLT-5822-30</b>	<b>2"x30' Ratchet Strap with Flat Hook</b>	<b>11.95 ea</b>
<b>MLT-4228</b>	<b>5/16"-3/8" Lever Binder</b>	<b>14.95 ea</b>
<b>MLT-4456-20-F</b>	<b>5/16"x20' Chain with Clevis Hooks</b>	<b>24.95 ea</b>
<b>031-01070</b>	<b>Stainless Steel Quarter Fender Set</b>	<b>99.95 ea</b>
<b>031-01636</b>	<b>Black Plastic Quarter Fender Set</b>	<b>59.95 ea</b>
<b>022-01087</b>	<b>Manifest Box</b>	<b>6.95 ea</b>
<b>ABP-N82-7318</b>	<b>Alliance 18" Wiper Blade</b>	<b>4.95 ea</b>
<b>ABP-N82-7320</b>	<b>Alliance 20" Wiper Blade</b>	<b>4.95 ea</b>
<b>ABP-N82-7322</b>	<b>Alliance 22" Wiper Blade</b>	<b>4.95 ea</b>
<b>BKS KD2205</b>	<b>Height Control Valve</b>	<b>54.95 ea</b>

**PARTS PICTURES ARE FOR REFERENCE ONLY. ACTUAL PARTS MAY VARY.**  
**Prices good through October 31, 2011**



# Alliance Exhaust **only at Freightliner / Western Star**



<b>ABP-N49-5FT18G</b>	<b>5"x18" Galvanized Flex Pipe</b>	<b>\$9.95 ea</b>
<b>ABP-N49-5FT24G</b>	<b>5"x24" Galvanized Flex Pipe</b>	<b>11.95 ea</b>
<b>ABP-N35-50PLA</b>	<b>5" Aluminized Pre-formed Exhaust Clamp</b>	<b>5.49 ea</b>
<b>ABP-N35-50PLS</b>	<b>5" Stainless Steel Pre-formed Exhaust Clamp</b>	<b>6.49 ea</b>
<b>ABP-N35-50EST</b>	<b>5" Stainless Steel Easy-Seal Flat Exhaust Clamp</b>	<b>5.95 ea</b>

Parts pictures are for reference only. Actual parts may vary. Prices good through October 31, 2011

## LONESTAR LABOR SPECIAL

**Don't get caught with a bad clutch in a bad place.**

**Clutch Adjustment**  
**\$45.00**

- **Come in for a clutch adjustment or a replacement if needed.**
- **A clutch replacement estimate for your truck is available at time of service.**
- **We service and replace all makes.**

If repairs are necessary, parts and labor will be at additional cost. Offer good through October 31, 2011



[www.LonestarTruckGroup.com](http://www.LonestarTruckGroup.com)

# Lonestar Truck Group MANAGERS' SPECIALS



**1999 Freightliner** CL11264S Columbia 112 Dump, C12 Caterpillar Engine 350 hp; Diesel; 10 Spd; Engine Brake; Air Ride; 2.92 Ratio; 22.5 LP Tires; Aluminum Outside Wheels; 210 in Wheelbase, 821,000 Miles, Fresh Engine Overhaul. (XLA63093-ABL-1) **\$28,500**



**2007 Freightliner** FLD132 Classic XL, Detroit Diesel DDC 14.0, 515 HP, 10 Spd, Engine Brake, Air Ride Suspension, 260" Wheelbase, 22.5 Tires, All Aluminum Wheels, Air Brakes, 555,032 Miles. Old (7DW78435-ABQ-1) **\$48,400 \$44,900**



**2000 International** 4000. International T444E Engine, 210 HP, Spring Suspension, 209" Wheelbase, 22.5 LP Tires, Steel Wheels, Air Brakes, 150,000 Miles. (YH674367-BRY-1) **\$8,500 \$6,300**



**2012 Western Star** 4900SA, Cummins ISX, 485 HP, 18 Spd, Tuff Trac Suspension, 4.30 Ratio, 227 in Wheelbase, 24.5 Tires, Aluminum Front Wheels, Steel Rear Wheels, New. (CPBL2661-FAR-1) **\$130,998**



**2005 Freightliner** Business Class M2 106, Diesel Caterpillar Engine 190 hp; Diesel Fuel Type; 6 Spd; Spring Suspension; 4.11 Ratio; 22.5 Tires; All Steel Wheels; Single Axle; 15 ft Length; 17,500 lb Rear Axle Weight; 8,000 lb Front Axle Weight. (2005 White Gang SAN-1) **\$59,500**



**2007 Freightliner** Columbia CL120, 70" Raised Roof Condo Sleeper, Detroit Diesel DDC 14.0, 455 HP, 10 Spd, Air Ride Suspension, 3.58 Ratio, 230" Wheelbase, 22.5 LP Tires, All Aluminum Wheels, 207,650 Miles. (7LY88990-SHV-1) **\$41,000**



**2009 Peterbilt** 387, Raised Roof Sleeper; ISX Cummins Engine 475 hp; Diesel; 10 Spd OD; Engine Brake; Air Ride Suspension; LP 22.5 Tires; All Aluminum Wheels; 228 in Wheelbase; Tandem Axle, 405,000 Miles. (9D775287-TEM-1) **\$75,500**



**2012 Freightliner** M2 106, Cummins ISC, 350 HP, Allison Automatic Transmission, Air Ride Suspension, 4.63 Ratio, 195 in Wheelbase, Aluminum Front Wheels, Aluminum Outer Rear Wheels, 22.5 LP Tires, This Crew Cab is Decked Out. New. (CDBE8216-TXK-1) **\$127,500**



**2012 Freightliner** Coronado SD, Cummins ISX, 500 HP, 10 Spd, 3.70 Ratio, 220 in Wheelbase, Aluminum Front Wheels, Aluminum Outer Wheels, 24.5 LP Tires, Warranty - Ask for Details. New. (CDBK0286-TYL-1) **\$120,417**



**2005 Freightliner** M2 106 Medium Duty, Standard Cab; C7 Caterpillar 210 hp; Diesel Automatic; Spring Susp; 24 ft Length; Lift End Gate; Roll up Door; 5.57 Ratio; 22.5 Tires; Steel Wheels; 270" WB; Single Axle, 195,000 Miles. (5HU59464-WAC-1) **\$26,000 \$25,500**



**2007 Freightliner** CL12064ST Columbia 120, 70" Mid Roof XT Sleeper; Detroit Engine 455 hp; Diesel; 10 Spd; Eng. Brake; Air Ride; 2.62 Ratio; 22.5LP Tires; Alum/Steel Wheels; 230" WB, 554,000 Miles. (7LW17837-WFF-1) **\$41,500**



**2000 Utility** Flat Bed, 48" x 102, Air Ride Suspension, Aluminum Floor, Wide Spread Air Ride, Set Forward Suspension. Sliding Winches, 22.5 LP Tires. (YA931330-SHV-TRL-1A) **\$Call For Price**



# Lonestar Truck Group is your place for quality used trucks.



**2008 Kenworth W900L**, 72" Aerodyne Sleeper; C15 Caterpillar Engine 550 hp; Diesel; 18 Spd OD; Engine Brake; Air Ride; 3.25 Ratio; 24.5 LP Tires; All Aluminum Wheels; 275" Wheelbase, 462,846 Miles. (8R228658-ABL-2) **\$79,500**



**2006 International 9900i**, 72 in Mid Roof Sleeper; ISX Cummins Engine 435 hp; Diesel; 10 Spd OD; Engine Brake; Air Ride Suspension; 22.5 Tires; Aluminum Outside Wheels; 260" WB, 722,500 Miles. (6C331036-ABL-3) **\$37,500**



**2007 Freightliner RHA114**, Crew Cab; MBE900 330 hp; Diesel; Auto OD; Engine Brake; Air Ride; 4.63 Ratio; 22.5 Tires; Alum-Whls; 187" WB; Singl.Ax; 11,500# Rear Ax Wt; 8,000# Frnt Ax Wt; 56,750 MIs (7HY17249-ABQ-2) **\$79,500**



**2006 Chevrolet 3500 LT Duty Truck**, Crew Cab; Duramax Chevy Eng 360 hp; Diesel; 120,000 mi; OD; 16 Tires; Single Axle; Ranch-Hand-bumpers, Warn-winch, leather-heated-memory-seats, -Bose-sound, 4x4 Onstar, gooseneck ball/fifth. (6F109434-ABQ-3) **\$27,900**



**2003 International 4000 Series**, Intl VT 365 Engine, 210 HP, Allison Automatic Transmission, Spring Suspension, 209 in Wheelbase, 138" Clear back of cab to center of axle, 71" Overhang, 195,000 Miles. (3N57943-BRY-2)



**2008 Freightliner C12064ST Century 120**, 70 in Raised Roof Condo; 14.0 Detroit Engine 500 hp; Diesel; 10 Spd OD; Engine Brake; Air Ride; 3.42 Ratio; LP 22.5 Tires; Aluminum Wheels; 230" WB; Tandem Axle, 475,000 Miles. (8LAB3321-BRY-3)



**2005 Kenworth W900L**, Cummins ISX, 400 HP, 13 Spd, Air Ride Suspension, 3.55 Ratio, 22.5 Tires, All Aluminum Wheels, 585,550 Miles. (5R075916-FAR-2)



**2007 Freightliner M2 Mercedes MBE 300**, 300 HP, Allison Automatic Transmission, Air Ride, 22.5 Tires, Aluminum Wheels, Air Brakes, Schwalbe Conversion, Loaded, Leather Seats, Great Sound System, DVD Player, 28,000 Miles. (7HY38622-FAR-3)



**2007 Peterbilt 379**, Caterpillar C15, 475 HP, 13 Spd, Engine Brake, 3.25 Ratio, Air Ride Suspension, 265 Wheelbase, 22.5 LP Tires, Aluminum Front Wheels, Aluminum Outer Wheels, 737,225 Miles. (7D673921-SAN-2)



**1994 Fontaine**, 48' x 102" Flatbed, 22.5 LP Tires, Air Ride Suspension, Hardwood Floors, Nice Trailer with Good Brakes and Tires, Needs a Couple of Boards in Floor. (R1562228-SAN-TRL-3)



**2012 Freightliner 114SD**, Detroit Diesel D13, 450 HP, 10 Spd, Air Ride, 3.70 Ratio, 210" WB, 24.5 LP Tires, All Aluminum Wheels, Warranty - Ask For Details. New. (CHBK1591-SHV-2) **\$110,917**



**2004 Peterbilt 379**, 63 in Stand Up Sleeper; C15 Caterpillar Engine 435 hp; Diesel; 13 Spd OD; Engine Brake; Low Air Suspension; 22.5 LP Tires; All Aluminum Wheels; 265" WB; Tandem Axle. Carrier APU Unit. (4D819827-SHV-3) **\$31,800**

See a complete inventory of new and used trucks and trailers online at: [www.LonestarTruckGroup.com](http://www.LonestarTruckGroup.com)



# Many models & colors to choose from.



**2008 Freightliner CL12064ST Century 120**, 70 in Raised Roof Condo; Diesel; 10 Spd OD; Engine Brake; Air Ride Suspension; 3.42 Ratio; LP 22.5 Tires; All Aluminum Wheels; 230 in Wheelbase; Tandem Axle, 542,000 Miles. (8LW48880-TEM-2)



**2012 Freightliner CC12264 Coronado SD**, DD 15 Detroit Engine 505 hp; Diesel; 10 Spd OD; Engine Brake; Air Ride; 3.55 Ratio; 11R 14.5 Tires; Aluminum/Steel Wheels; 215 in Wheelbase; Tandem Axle, New. (CDBH0752-TEM-3)



**2007 Western Star 4900**, 36 in Hi Rise Sleeper; DDC 14.0 Detroit Engine 500 hp; Diesel; 10 Spd OD; Engine Brake; Air Ride; Aluminum Outside Wheels; 232 in Wheelbase; Tandem Axle, 398,645 Miles. (7PY55249-TXK-2) ~~\$64,880~~ **\$64,500**



**2006 Kenworth W900**, C15 Caterpillar Engine 475 hp; Diesel; 18 Spd OD; Engine Brake; Air Ride Suspension; 24.5 Tires; Aluminum Wheels; 235 in Wheelbase; Tandem Axle, 485,000 Miles. (6J110320-TXK-3) **\$67,500**



**2007 International 400 Medium Duty**, Standard Cab; DT466 International Engine 215 hp; Automatic; Diesel Fuel Type; Nice Clean Flatbed Truck, 307,423 Miles. (7H525170-TYL-2) **\$24,877**



**2012 Freightliner 114SD**, Detroit Diesel D13, 450 HP, 10 Spd, Air Ride Suspension, 3.70 Ratio, 210 in Wheelbase, Steel Front - Aluminum All Rear, 24.5 LP Tires, Warranty - Ask for Details. New. (CHBK1589-TYL-3) **\$111,880**



**2006 Freightliner CL12064ST Century 120**, 58" Mid Roof Sleeper; Mercedes Engine 450 hp; Diesel; 10 Spd OD; Engine Brake; Air Ride; 3.58 Ratio; 11R 24.5 Tires; All Aluminum Wheels; 230" WB; Tandem Axle, 515,000 Miles. (6DW80886-WAC-2)



**2008 Freightliner CL12064ST Century 120**, 70 in Raised Roof Condo; 14.0 Detroit Engine 500 hp; Diesel; 10 Spd OD; Engine Brake; Air Ride; 3.42 Ratio; LP 22.5 Tires; All Aluminum Wheels; 230" WB; Tandem Axle, 418,000 Miles. (8LAB3433-WAC-3)



**2007 Peterbilt 379 EXT**, Caterpillar C15, 475 HP, 13 SPD, 70" Sleeper, Air Ride Suspension, 3.25 Ratio, 265" Wheelbase, Aluminum Front Wheels, Aluminum Outer Rear, 22.5 LP Tires, 760,000 Miles. (7D673941-WFF-2)



**2012 Western Star 4900FA**, (Qty: 3) DD15 Detroit Engine 505 hp; Diesel; 10 Spd OD; Engine Brake; Air Ride Suspension; 3.70 Ratio; 11R24.5 Tires; All Aluminum Wheels; 220 in Wheelbase; Tandem Axle, New. (CPBL2636-WFF-3)



**2004 Utility Flat Bed**, Air Ride Suspension; 48 ft Length x 102 in Width; Aluminum Floor; 22.5 LP Tires; Steel Disc Wheels; Spread Axle; Combination Composition, WSAR Financing Available. (4A304604-TYL-TRL-3b)



**1998 Galyean 4-Bunk Log**, Spring Suspension; 40 ft Length; 24.5 Tires; Steel Disc Wheels; Fixed Tandem Axle; Steel Composition; Call for more details. (WHO15604-TXK-TRL-3b) **\$10,000**

Lonestar Truck Group  
2051 Hughes Road  
Grapevine, TX 76051

PRESORT STANDARD  
U S POSTAGE  
PAID  
GLOBAL MAIL

RETURN SERVICE REQUESTED



Your one-stop source for  
**TRUCK and TRAILER SALES, PARTS and SERVICE**



SCAN ME  
FOR FULL  
INVENTORY



www.LonestarTruckGroup.com • LS-1293 InGear Newsletter • ©Lonestar Truck Group, October 2011

## Online Invoices and time critical info put **You** in charge.

### Stay Informed 24/7 with Lonestar's Online Invoices.

Viewing your invoices online is as easy as **1 - 2 - 3**:

- 1)** Register to create your online account.
- 2)** Wait for notice that your account has been authorized.
- 3)** You can then login to access your invoices for viewing and printing.



[www.LonestarTruckGroup.com](http://www.LonestarTruckGroup.com)